



FrameFrog 4 Port Short Model: FRG4S



Installation
Instructions

Electrified Hardware Back-Box Assembly for Wired Door Hardware

Specifically designed for an easy, professional solution to all electronic access control systems. Replaces the door frame metal mortar box where wired hardware is installed, providing a smooth, seamless pathway while future-proofing door hardware wiring access.

Features

1. Suitable for electronic locks, strikes, card readers, position switches, or any other devices for wired access control systems.
2. Compatible with hollow metal masonry and drywall type door frames.
3. Four connection points for universal wiring configurations.
4. Limited for Class 2 Single Source power supplies only with system wiring voltage of 30 volts or less.
5. Fits Standard Profile Hollow Metal Frames from 5 3/4" to 9 1/4" in depth.
6. Removable port caps left in place protect the back box from mortar intrusion.
7. Optional adjustable Wing Tabs for shop or field installation. (Sold separately).

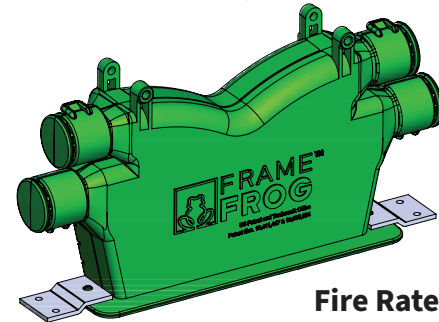

**Fire Rated for Door
Frames up to 3 Hours.**

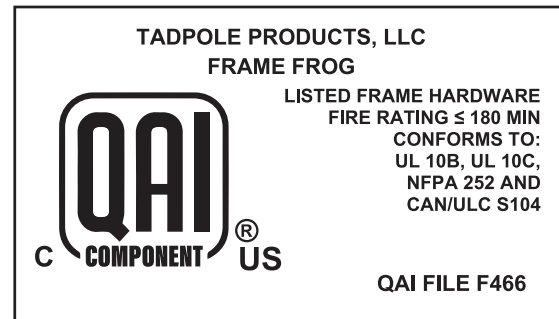

Benefits

1. Patented design seamlessly directs a fish tape directly into the connected conduit.
2. Divider walls guide a fish tape to your chosen conduit path with the flick of a finger.
3. Wiring pathways are easily accessible through entry point even after construction is complete.
4. Easily fish additional wiring for last minute changes or repairs.
5. Future-proof doors for any potential needed security or data needs.

Key Specifications

Material	ABS Plastic
Number of Ports	4
Max. Frame Opening	5" Long Prep
PVC Conduit	1/2"
Port Diameter	.871" Inside Diameter
Conduit Size and Type	1/2" PVC (Not Provided)
Frame Depths	5 3/4" to 9 1/4" Depth
Frame Types	Masonry, Drywall, Hollow Metal
Adhesive	Multipurpose for PVC to ABS Plastic

US Patent and Trademark Office
Patent Nos: 10,411,447 and 10,855,064



Tadpole Products, LLC
223 Fairfield Ave, Suite 100
Bellevue, KY 41073
513.381.2112
www.framefrog.us

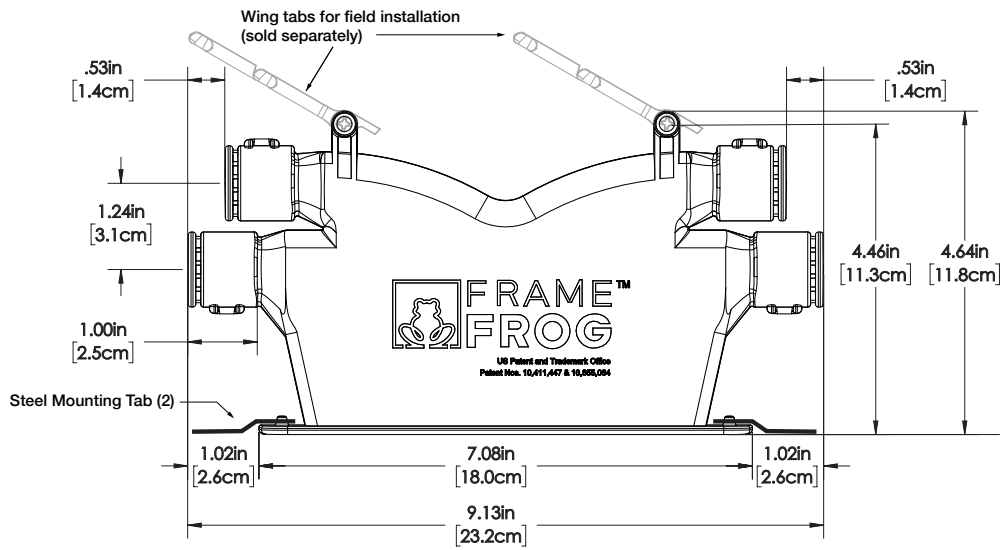

FRONT VIEW

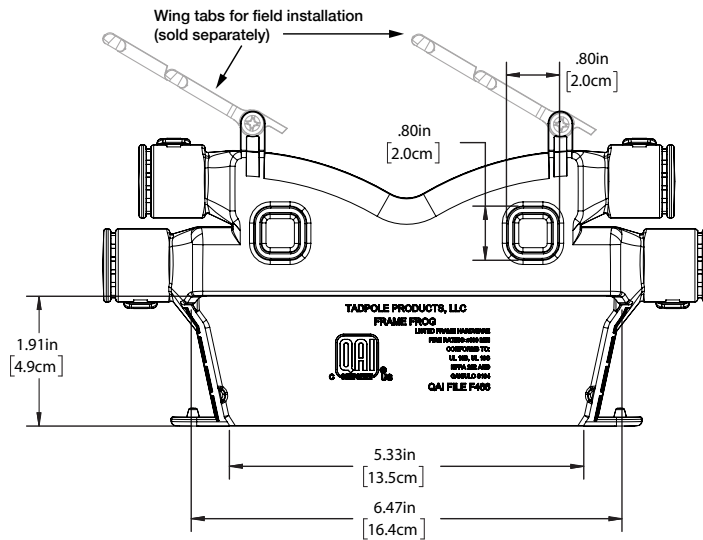

REAR VIEW

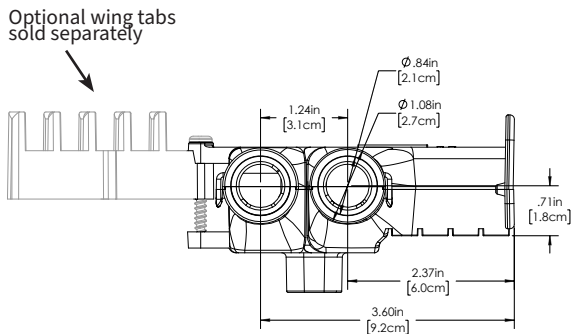

END VIEW

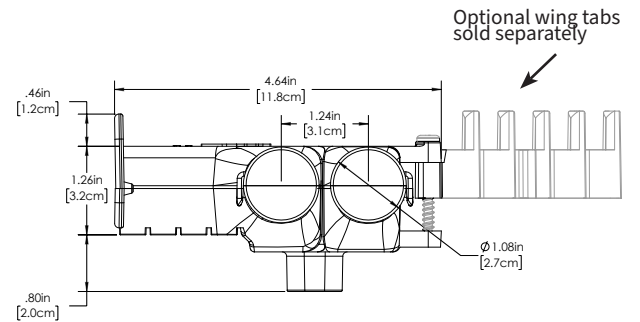

END VIEW



Tadpole Products, LLC
 223 Fairfield Ave, Suite 100
 Bellevue, KY 41073
 513.381.2112
 www.framefrog.us

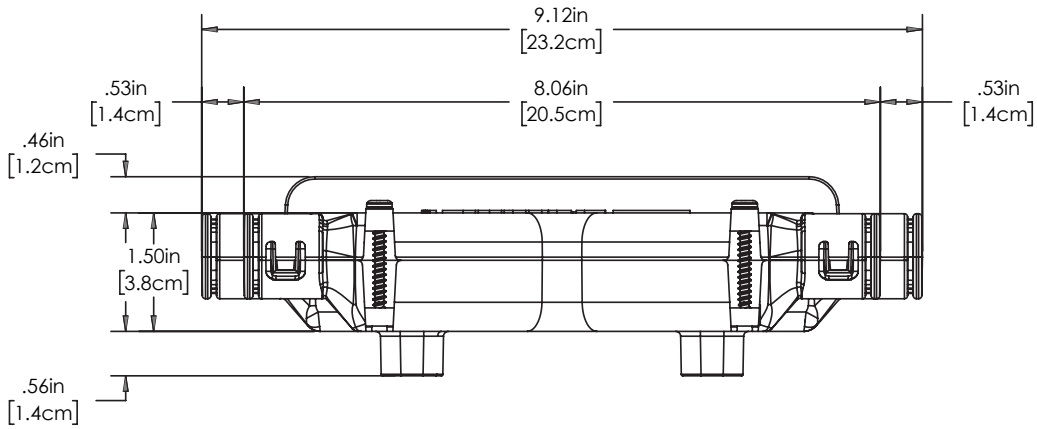

TOP VIEW

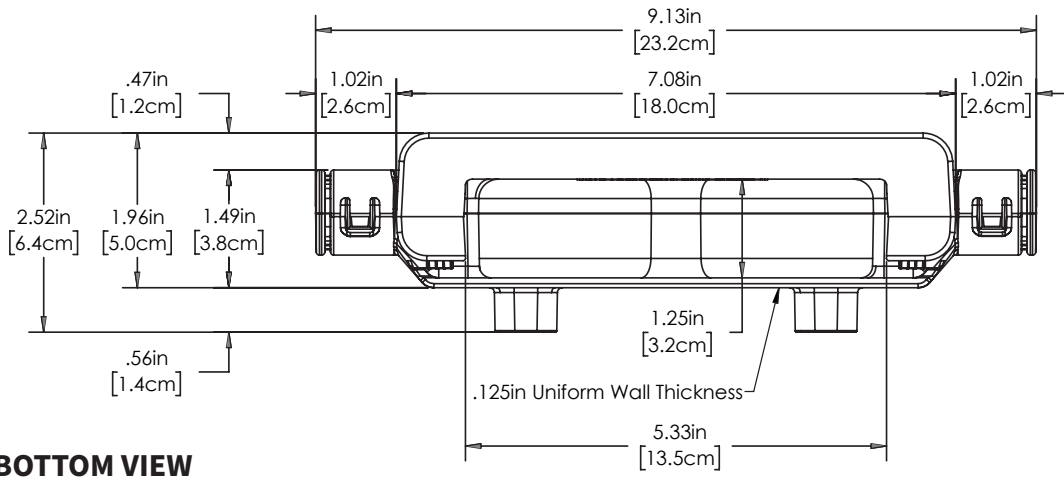

BOTTOM VIEW

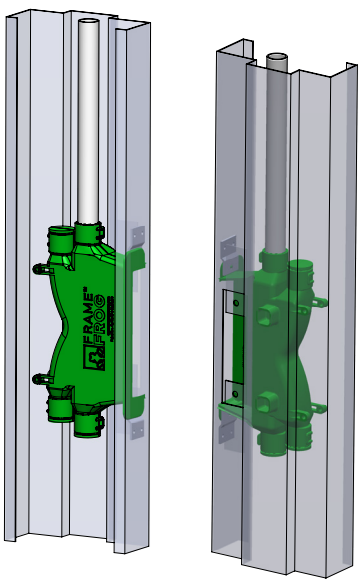

Offset port design provides added clearance for standard 90° conduit to turn down and remain within the frame.

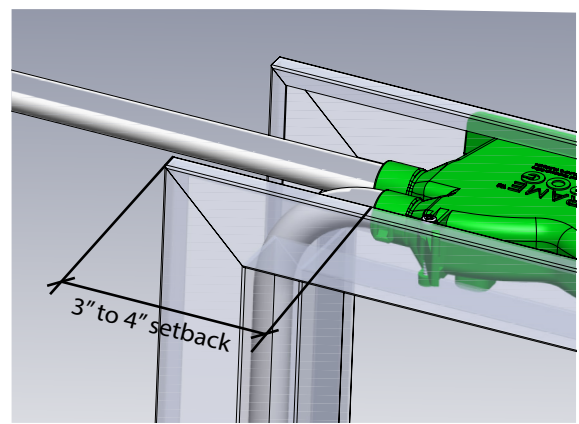

Tadpole Products, LLC
 223 Fairfield Ave, Suite 100
 Bellevue, KY 41073
 513.381.2112
 www.framefrog.us

Material

Acrylonitrile Butadiene Styrene (ABS)

ABS HI 121 by LG Chem

Properties	Test Condition	Test Method	Unit	Typical Value
Physical				
Specific Gravity		ASTM D792		1.04
Melt Flow Rate	220° C/10kg	ASTM D1238	g/10min	21
Mechanical				
Tensile Strength, 3.2mm @ Yield	50mm/min	ASTM D638	kg/cm ²	460
Tensile Elongation, 3.2mm @ Break	50mm/min	ASTM D638	%	40
Flexural Strength, 3.2mm	15mm/min	ASTM D790	kg/cm ²	740
IZOD Impact Strength, 6.4mm (notched)	23°C	ASTM D256	kg-cm/cm	32
IZOD Impact Strength, 3.2mm (notched)	23°C	ASTM D256	kg-cm/cm	35
Thermal				
Heat Deflection Temperature, 6.4mm, (Unannealed)	18.6kg	ASTM D648	C°	87
	4.6kg	ASTM D648	C°	91
Vicat Softening Temperature	5kg, 50°C/h	ASTM D1525	C°	93
Flammability		UL 94		HB

ABS MATERIALS NOTE: Typical values are only for material selection purpose, and variation within normal tolerances are for various colors. Values given should not be interpreted as specification and not be used for part or tool design. All properties, except melt flow rate, are measured on injection molded specimens and after 48 Hours storage at 23°C and 50% relative humidity.



Tadpole Products, LLC
 223 Fairfield Ave, Suite 100
 Bellevue, KY 41073
 513.381.2112
www.framefrog.us